



## DIGGING DEPTH

7'2"

## OUTPUT RATING

14.1HP

## OPERATING WEIGHT

4,261 LBS

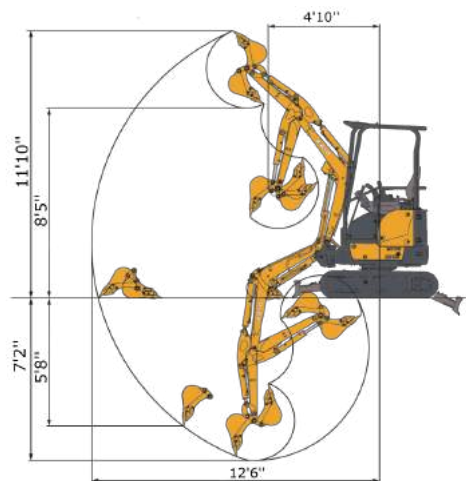
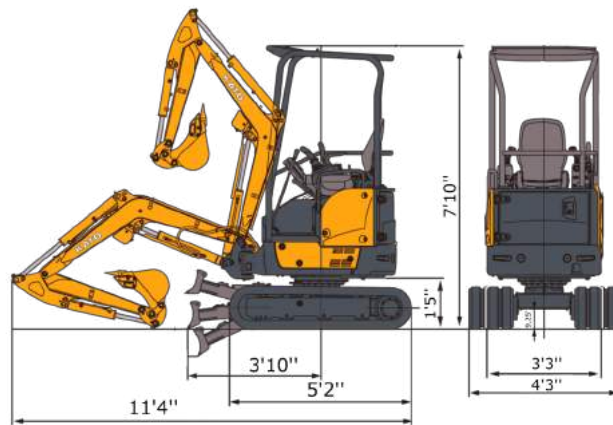

### 17V5

Working Ranges

A.	Max digging radius	12'6"
B.	Max digging depth	7'2"
C.	Max vertical dig depth	5'8"
D.	Max dumping height	8'5"
E.	Max digging height	11'10"
F.	Min. front-turn radius	4'10"
G.	At right boom swing	4'5"

# KATO

# HD HD 17V5

MODEL	HD17V5
<b>PERFORMANCE</b>	
Bucket Capacity	1.6 ft <sup>3</sup>
Bucket Width	12"
Operating Weight	4,261 lbs
Transport Weight	3,924 lbs
Swing Speed	8.5 rpm
Travel Speed (Low/ High)	1.3 mph / 2.5 mph
Gradeability	30°
Ground Pressure	4.4 psi
Bucket Digging Force	4,842 lbs.
<b>Engine</b>	
Model	YANMAR 3TNV74F
Output Rating	14.1 hp / 2,300rpm
Fuel Tank Capacity	5.8 gallons
<b>Boom Swing System</b>	
Type	Offset Boom w/ Hydraulic Cyl.
Swing Angle (L / R)	55° / 70°
<b>Hydraulic System</b>	
Total Hydraulic System Flow	12 gpm
Max Auxiliary Hydraulic Flow	7 gpm
<b>Dozer Blade</b>	
Size	3' 3" x 9.25"
Lift Above / Drop Below Ground	11.8" / 9"

# KATO

EXCAVATORS AND TRACK LOADERS

[www.KATOCES.com](http://www.KATOCES.com)

400 Production Court

Elizabethtown, KY 42701

(800) 538-1447 | Fax: (270) 737-0419