

Model Number: 24-W-1000

Serial Number: \_\_\_\_\_

# **THE HURRICANE**

---

---

# **MODEL 24**

# **DITCHER-TERRACER**



## **HURRICANE DITCHER CO., INC.**

2425 Cathlinette Rd.  
Vincennes, IN 47591

812-886-9663 Fax 812-886-0530

[www.hurricane-ditcher.com](http://www.hurricane-ditcher.com)

e-mail: [info@hurricane-ditcher.com](mailto:info@hurricane-ditcher.com)



Updated : March 2021

TABLE OF CONTENTS

---

INTRODUCTION..... 3  
SPECIFICATIONS OF THE MODEL 24 DITCHER-TERRACER ..... 3  
SAFETY PRECAUTIONS ..... 4  
WARNING LABELS & ILLUSTRATION..... 5  
TRANSPORTATION..... 6  
UNHITCHING FROM TRACTOR..... 6  
USING THE MODEL 24 DITCHER-TERRACER..... 7  
CHECKLIST BEFORE OPERATION..... 7-8  
OPERATING INSTRUCTIONS ..... 8-9  
MAINTENANCE ..... 9  
LUBRICATION ..... 10  
FREE MOVEMENT OF DRIVELINE ..... 11  
IDLER ADJUSTMENT ..... 11  
PARTS LIST & ILLUSTRATION – STRUCTURAL COMPONENTS..... 12-13  
PARTS LIST & ILLUSTRATION – MECHANICAL COMPONENTS ..... 14-15  
PARTS LITS & ILLUSTRATION – OPTIONAL COMPONENTS ..... 16-17  
LIMITED WARRANTY..... 18  
MAINTENANCE LOG ..... 19



**CAUTION!!!!**

- Read the Operator’s Manual.
- Learn to operate this machine SAFELY.
- Be alert. Observe ALL Safety Practices.
- Machines can be hazardous in the hands of an UNFAMILIAR, UNTRAINED or COMPLACENT operator.
- Do not risk INJURY or DEATH!

## INTRODUCTION

---

Thank you and congratulations on the purchase of your Hurricane Ditcher Model 24 Ditcher-Terracer. We certainly hope that it will be helpful and useful to you. As with all of our ditchers, it has been tested and built with knowledge, precision, and quality for years of dependable service. As a leader in the ditching industry since 1984, we continually build on our experience and use customer feedback to maintain and improve the quality and dependability of our machines.

In order to fulfill a need in agriculture, the Model 24 Ditcher-Terracer was developed in 1986 as an efficient and affordable machine to make surface drainage ditches, to construct and clean waterways and to build and maintain terraces using a standard farm tractor. It has become increasingly popular among soil conservation districts for cleaning waterways and rebuilding terraces. Whatever your application, we hope it works well for you.

Please read and follow all safety precautions, operating procedures and maintenance requirements. Following these recommendations will prevent injury and operation down time. Proper maintenance and lubrication will prevent machine breakdown and increase its life expectancy, which will lead to better performance for you.

Please let us know of any comments, suggestions, or problems that may arise.

HURRICANE DITCHER CO., INC.  
2425 Cathlinette Road  
Vincennes, IN 47591  
812-886-9663  
www.hurricane-ditcher.com  
info@hurricane-ditcher.com

***YOUR AUTHORIZED HURRICANE DITCHER DEALER:***

## SPECIFICATIONS OF THE MODEL 24 DITCHER-TERRACER

---

- HP required: 100 to 180 HP on 1000 RPM PTO
- Width of cut: 24 inches plus taper on each side
- Depth of cut: up to 10 inches in a single pass; up to 28 inches in multiple passes
- Volume of soil moved: with 100 HP tractor, up to 300 tons per hour (5 tons per minute); with 140 HP tractor, up to 1,080 cubic yards per hour (18 cubic yards per minute)
- Weight of machine: approximately 3,200 pounds without optional components; approximately 3,600 pounds with optional components; tongue weight approximately 1,200 pounds
- Drive train: 55 series PTO with shear bolts which overload at the tractor end; 1-3/4 inches diameter drive shaft from PTO to gear box; double 80 roller chain with idler adjustment
- Certain brands of tractors could require different length PTO and/or hydraulic hoses. Contact your dealer for detailed specifications.

---

**SAFETY PRECAUTIONS**

---



**OBSERVE THIS SYMBOL THROUGHOUT THIS MANUAL.** It calls out potential hazards and dangers. This symbol will be associated with a key SIGNAL WORD that will designate a degree or level of hazard seriousness. These signal words are as follows:



**DANGER!** Indicates an imminently hazardous situation that, if not avoided, **WILL** result in death or serious injury; a danger that safety guards cannot protect against.



**WARNING!** Indicates a potentially hazardous situation that, if not avoided, **COULD** result in death or serious injury, and includes hazards that are exposed when guards are removed; also an alert to unsafe practices.



**CAUTION!** Indicates a potentially hazardous situation that, if not avoided, **MAY** result in minor or moderate injury; also an alert to unsafe practices.

**INTENDED USE: MODEL 24 is designed to be pulled by a ROPS- equipped tractor of proper size. It is not to be used in any other purpose other than its intended use.**

**BEFORE OPERATION:**

- Carefully study and understand this manual. Be sure the operator has read and understands all operations before using this machine.
- Do not wear loose-fitting clothing which may catch in moving parts.
- Learn to operate this machine safely. Be alert and observe all safety practices. Machines can be hazardous in the hands of an unfamiliar, untrained or complacent operator. Never risk injury or death!
- After servicing, be sure all tools and servicing equipment have been removed from the machine.
- Be certain there is no one near the machine before starting.
- Do not stand under or near deflector or terracing shield.
- Do not use the ditcher until you are **certain** that the area in which you are preparing to work is clear. Be especially watchful for people, animals and moving vehicles that may enter the discharge path. Remember, soil may be thrown over 100 feet. Rocks and other debris may go farther, so use extreme caution in any area with buildings or objects that could be damaged from flying debris.



**WARNING!** Do not operate this machine above 1000 RPM. Excessive speed of PTO can be dangerous and could cause personal injury or damage to your tractor or ditcher.



**WARNING!** Do not exceed recommended horsepower (180 HP or less) for this machine. Excessive horsepower can be dangerous.

- Before each use, inspect the lower shaft behind the impeller wheel for material wrapped around shaft. Failure to keep shaft clear could result in bearing failure and is not covered under warranty.

**DURING OPERATION:**

- Keep all shields in place.
- Allow no one to stand on the left side (discharge side) of the machine while it is in operation, whether it is moving or standing still.
- **NO PASSENGERS ALLOWED!** Do not allow anyone to ride on ditcher at any time.

- Keep clear of all moving parts.
- Disengage the PTO and shut off tractor engine before servicing, cleaning or clearing a clogged machine.
- Avoid overhead wires; contact could cause serious injury or death.

### WARNING LABELS & ILLUSTRATION

---

Your MODEL 24 comes equipped with all safety labels in place. These safety labels are designed to help you safely operate your equipment. They inform you about possible hazards associated with the normal operation or foreseeable misuse of the product and how to properly avoid those hazards to prevent physical injury or death. You are required to read and follow their directions.

1. Keep all safety labels clean and legible.
2. Replace all damaged or missing labels.
3. New equipment installed during repairs may require replacement safety labels to be affixed or replaced part, if missing, as specified by Hurricane Ditcher Co.
4. Contact your local dealer to order replacement labels.
5. Refer to this section for proper label placement. When installing new labels:
  - a. Clean placement surface with soapy water or surface cleaning solution and allow to dry.
  - b. Peel backing from label, carefully center and place label in proper location ensuring no creases or air pockets
  - c. Press label firmly onto the surface and use a straight edge to smooth the label on the machine for a secure adhesion

<u>ITEM</u>	<u>PART #</u>	<u>DESCRIPTION</u>
A1	009050	<b><u>IMPORTANT</u></b> – BE SURE TO HOOK PTO UP PROPERLY
C1	009010	<b><u>DANGER</u></b> – STAY CLEAR OF MACHINE WHEN IN OPERATION
D1	009020	<b><u>DANGER</u></b> – ROTATING DRIVE LINE
E1	009040	<b><u>WARNING</u></b> – KEEP ALL SHIELDS IN PLACE
F1	009060	<b><u>WARNING</u></b> – DANGER OF FALLING DEBRIS

**Note:** Manufacturer will replace safety decals upon request when worn, damaged or missing.

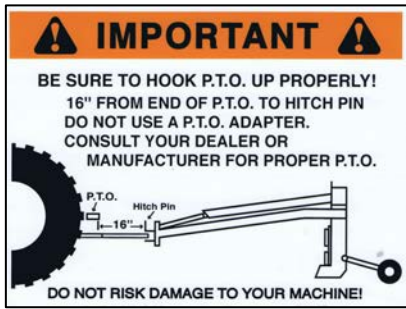

A1

F1

C1



D1



E1





## TRANSPORTATION

Check with local law officials to see if lights, flags, slow moving vehicle signs or other safety devices are required for transporting and ALWAYS install the cylinder transport lock (See page 13 item #G4).

After hitching to transport vehicle (See illustration below):

- Place the jack with pin in the transport mount.
- Place the front PTO shaft in the provided transport holder.

If your machine is equipped with a terracing shield, make sure the cylinder is fully retracted so the shield is in a vertical position and secured with the transport lock to hold this position. Always use extreme caution when transporting your machine with the terracing shield and extension attached as it can exceed 14 feet in height (the deflector shield can exceed 11 feet in height). If there are low tree limbs and wires, it is advisable to remove the terracing shield extension before moving (See page 17 item #R21).

Your Model 24 may be moved between job sites with a ¾ ton pickup truck providing it is equipped with a heavy-duty hitch and the brakes are in good operating condition. NOTE: Tongue weight is approximately 1,200 pounds and the gross weight is approximately 3,200 to 4,000 pounds requiring extra distance to stop safely.

If you will be transporting your ditcher on a trailer, make sure the machine is safely secured. It may cause injury to yourself or others, or damage the machine if it is not securely tied down. You may wish to place boards under the tongue and cutting edge to prevent damage to the floor of your trailer. The terracing shield and extension must be removed before transporting on a trailer. The deflector shield may not need to be removed before transporting on a trailer. Always check height to verify you are within DOT limits.

## UNHITCHING FROM TRACTOR

- 1) Park on level ground far enough from obstacles so that the terracing shield may be lowered.
- 2) Lower the terracing shield and apply a thin coat of grease to the exposed hydraulic cylinder rod to prevent rusting and corrosion. NOTE: Hydraulic cylinders with nitro rods do not need to be greased. IF YOU WISH TO LEAVE THE TERRACING SHIELD IN THE UPRIGHT POSITION, IT MUST BE SECURED WITH THE SHIELD TRANSPORT LOCK.
- 3) Install the cylinder transport lock (See page 13 item #G4)
- 4) Release hydraulic pressure. This may require shutting off the engine.
- 5) Disconnect the quick couplers from your tractor. NOTE: Always clean the quick couplers before reconnecting them to any hydraulic system.



**WARNING!** Always shut tractor engine off before unhooking PTO.

- 6) Pull the PTO safety slide lock (See page 15 item #L5) back on the PTO and remove from tractor spline. Separate the front half of the PTO and place it in its holder (See illustration below).
- 7) Replace jack and pin on frame mount (See illustration below).
- 8) Crank the ditcher jack down until it touches the ground. Do not apply pressure until hitch pin has been removed.
- 9) Pull the hitch pin. Apply pressure on the jack.
- 10) Drive vehicle away.

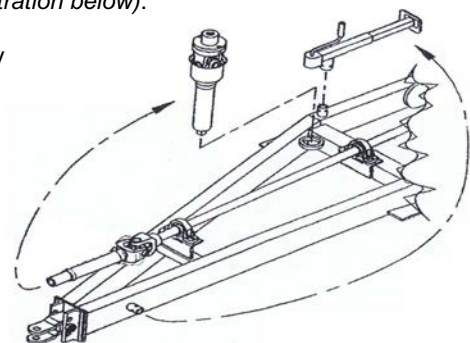

---

### USING THE MODEL 24 DITCHER-TERRACER

---

Each customer will use their machine for different purposes and in slightly different ways. We cannot tell you the proper way to use your machine for your particular purpose, but we can make recommendations for various uses.

**BUILDING OR REWORKING A DRAINAGE DITCH** – The ditcher throws soil and debris to the left side. When possible, it is more efficient if the soil is thrown to both sides of the ditch or waterway. To do this, make your first pass in the center of your ditch or waterway. After turning around make your second pass in the opposite direction with the right wheel of your tractor and the machine in the cut you just made. Operate the machine's cutting edge 5 to 8 inches deep and travel about 2½ miles per hour. If the ditch or waterway needs to be deeper, start in the center again and work outward. Even if you have excess horsepower it is best not to cut over 8 inches deep. Running 5 to 8 inches deep per pass allows a natural slope to the center of the area you are working. This same process is used when cleaning a terrace channel.

**RESHAPING OR BUILDING A TERRACE** – The terracing shield would be lowered to build up your terrace when traveling in one direction and raised scattering the soil back up the hill when traveling the other way. This procedure allows you to increase the water capacity of your terrace without a high terrace ridge and also allows your good topsoil to be distributed back into the area where it is needed.

This machine can be used to clean small roadside ditches, as well. (Remember, the soil is thrown out the left side of the machine. Soil may also be distributed over a 100 foot area. Rocks and other debris may go farther.) When straddling a roadside ditch it may be necessary to adjust the axles on your ditcher. They can be moved inward so they will go between the banks of the ditch or can be moved outward to run on the banks. It may also be necessary to move the hitch to the top hole. This will allow the ditcher to operate deeper. The maximum depth of cut is approximately 28 inches depending on how your tractor is set up.

---

### CHECKLIST BEFORE OPERATION

---

- Read and understand the operator's manual.
- Read all information on the safety decals on the machine.
- Check all bolts to make sure they are tight.
- Before connecting to tractor PTO and as general daily maintenance, check for free movement of driveline and/or slack in chain (*See Free Movement of Driveline section on page 11*).



**WARNING!** When hooking your tractor up to the ditcher, the distance from the end of the tractor PTO to the hole in the drawbar must be 16 inches, unless optional hitch and splined PTO are used.



**WARNING!** Do not operate this machine above 1000 RPM. Excessive speed of PTO can be dangerous and could cause personal injury or damage to your tractor or ditcher.

- Check that all hydraulic hoses are secured and will not interfere with the tractor wheels, PTO shaft or any other part.
- Be sure the PTO is hooked up correctly and will not interfere with the drawbar strap on the tractor.



- Be sure the hitch is secure.
- Check your tractor's hydraulic oil reservoir level (*See Lubrication section on page 10*).
- Lubricate machine (*See Lubrication section on page 10*).
- Check PTO forward travel. PTO must slide freely and must not bottom out or damage to bearings and shaft may occur.
- Before running machine each season or once per year, remove the shear bolts and lock nuts from the PTO shear yoke assembly to verify that the shear yoke is not corroded and will move freely. Reinstall shear bolts and lock nuts after inspection is complete.
- Do not operate this machine with a quick attach hitch on the tractor as damage to PTO shield will likely occur.

### OPERATING INSTRUCTIONS

---

- 1) Keep all shields in place.
- 2) Keep hands, feet and clothing away from all moving parts.
- 3) Do not allow anyone to ride on this equipment at any time.
- 4) Learn to operate this machine safely. Be alert and observe all safety practices. Machines can be hazardous in the hands of an unfamiliar, untrained or complacent operator. Do not risk injury or death!
- 5) Do not allow anyone to stand on the left side (discharge side) of the machine while it is in operation, whether it is moving or standing still.
- 6) Do not stand under or near deflector or terracing shield.
- 7) Disengage PTO and shut off tractor engine before servicing, cleaning or clearing a clogged machine.
- 8) When the machine is in operation, keep in mind that soil, roots, rocks and other debris may be thrown 150 feet or more out the discharge side causing damage to an object or harm to a person within its range.
- 9) It is recommended that the PTO be disengaged when turning around. **DO NOT MAKE SHARP TURNS WHILE PTO IS TURNING.**
- 10) Remove quick hitch from the tractor before operating. It is likely to dent PTO shield in sharp turns.
- 11) Use rubber straps to secure hoses on the tractor to keep them from getting into the PTO, otherwise damage may occur.
- 12) Be sure to keep the slip shaft portion (*See page 15 item L9*) of the PTO shaft well lubricated (*See Lubrication section on page 10*).
- 13) Do not engage PTO when tractor is running at high RPM. Slow RPM to idle before engaging PTO.
- 14) There are two (2) shear bolts in the PTO shaft (*See page 15 item L4*). If these bolts shear, stop the tractor, disengage the PTO, shut off the tractor engine, and replace the sheared bolts.



**WARNING!** Shear bolts are designed to break under a specified load. Do not use a stronger bolt than is specified by manufacturer!

- 15) The impeller has four (4) shear bolts. One (1) near the end of each paddle (*See page 15 item M2*). If a rock or other object is fed into the impeller, these bolts may shear and the paddle(s) will swing back out of the way. When this happens, stop the tractor, disengage the PTO, shut off the tractor engine and replace the sheared bolts.
- 16) In normal conditions, when mud or trash becomes a problem, stop forward travel and allow the machine to clear itself before moving ahead. NOTE: Optional heavy debris paddles can be used for extremely trashy conditions (*See page 17 item S3*).
- 17) When using the terracing shield, adjust the height with the hydraulic cylinder in order to place the discharged soil where it is needed. NOTE: Remember the terracing shield extends 8 feet beyond the left side of machine when attached. Use caution near fences, trees or objects on the road.



**WARNING!** When hooking your tractor up to the ditcher, the distance from the end of the tractor PTO to the hole in the drawbar must be 16 inches, unless the optional hitch and splined PTO are used.



**WARNING!** Do not operate this machine above 1000 RPM. Excessive speed of PTO can be dangerous and could cause personal injury or damage to your tractor or ditcher.



**WARNING!** Do not exceed recommended horsepower (180 HP or less) for this machine. Excessive horsepower can be dangerous and could cause personal injury or damage to your tractor or ditcher.



**WARNING!** Do not operate this machine unless the Scoop and Lower Impeller Shroud Assembly is bolted into place (*See page 13 item #J5*). This assembly cuts soil loose and feeds it into the revolving impeller paddles, greatly reducing the shock to the paddles. To operate the machine without this assembly in place could be extremely dangerous to the operator or others nearby and will cause damage to the machine.



**WARNING!** Do not use this machine with a PTO adaptor. The Agricultural Driveline Manufacturers Association and The Association of Equipment Manufacturers discourage the use of PTO adaptors due to serious safety and operational concerns.

## MAINTENANCE

---

If you are not going to use your machine for a period of time, paint the areas where the soil has worn off the paint (for example: cutting edge and paddles). You should also apply a thin coat of grease to the exposed hydraulic cylinder rod(s) to prevent rusting and corrosion. Storing inside or covering with a tarp will extend the life of your ditcher.

After approximately every ten (10) hours of use, disconnect from tractor and check for the free movement of driveline and proper chain tension (*See Free Movement of Driveline section on page 11*).

When the cutting edge wears out, unbolt it and replace with a new cutting edge. When the impeller paddles are slightly worn, weld with a hard surfacing rod on each paddle to build them back up. Use a welding rod that is equal to a 60RC Rockwell hardness. NOTE: Be sure to add the same amount of material to each paddle to keep the impeller assembly in balance. Replace paddles when worn flush with the impeller wheel.

If any component of your ditcher appears to be worn and needs replacement, please contact your dealer for replacement parts.

## LUBRICATION

The Model 24 Ditcher-Terracer has 12 grease fittings. Refer to the Illustration below for the location of these fittings. Read carefully the information below on lubricating those areas.

NOTE: Damage may occur due to improper lubrication.

**A – DAILY** (every 8 hours) – Grease the following with gun grease:

- 1 – The slip joint between PTO halves (remove from tractor, separate halves, apply gun grease to shaft, and reassemble).
- 2 – The two (2) universal joints at the ends of each PTO half and one (1) universal joint at the gearbox end of the drive shaft. Slowly apply grease as to not overgrease and blow out seals.
- 3 – Two (2) fittings on the axle pivot assembly.
- 4 – Check your tractor's hydraulic oil reservoir level. If system is empty (as when new), the ditcher's cylinder will require approximately 3/4 gallon of oil. Use a quality hydraulic oil of your choice.

**B – 24 HOURS OF OPERATION**

- 1 – Check the enclosed gearbox oil level. Fill to the oil level check plug (about 8 inches above bottom) on back side of gearbox. The factory installed gearbox oil is Trueblood ISO 680 industrial gear oil. Use of this oil is recommended as it is specifically formulated for peak performance of your Hurricane Ditcher.

**C – 40–60 HOURS OR 1–2 WEEKS OF OPERATION** – Grease the following with gun grease:

- 1 – Four (4) flange ball bearings on gearbox – 1 pump each. Slowly apply grease as to not overgrease and blow out seals.
- 2 – Two (2) pillow block bearings on drive shaft – 1 pump. Slowly apply grease as to not overgrease and blow out seals.

**D – 100 HOURS OF OPERATION**

- 1 – Remove the inspection plate on the back of the gearbox; check for wear on bearings, sprockets, chain, and idler; and adjust the idler assembly as required (*See Idler Adjustment section on page 11*). Reinstall inspection plate using quality grade silicone sealant under the inspection plate.

**E – YEARLY**

- 1 – Check and repack wheel bearings.

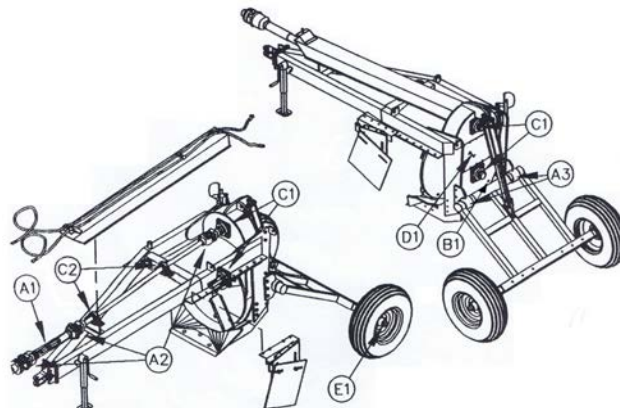

## FREE MOVEMENT OF DRIVELINE

When adjusted properly and operating correctly, the driveline should move freely by hand with no slack in the chain.



**WARNING!** Operation of improperly adjusted machine will cause damage to your ditcher and possibly to your tractor!



**WARNING!** Do not use your ditcher with a PTO adaptor. The Agricultural Driveline Manufacturers Association and The Association of Equipment Manufacturers discourage the use of PTO adaptors due to serious safety and operational concerns.

To check for free movement of driveline and proper tension on chain:

**Step 1** – Grasp the front PTO yoke and quickly rock it back and forth. If the PTO moves before the impeller turns, the chain requires tightening (*See Idler Adjustment section below*).

**Step 2** – If the impeller is difficult to move, check for debris lodged in the machine. Remove any interfering debris and return to Step 1. If no interferences are found, continue to Step 3.

**Step 3** – Check the pillow block bearings on the drive shaft. If damaged, repair as needed and return to Step 1. If no damage is found, continue to Step 4.

**Step 4** – Remove the inspection plate on back of the gearbox and carefully inspect bearings, sprockets, chain, and idler for damage. If damage is found, repair as needed, reinstall inspection plate using quality grade silicone sealant under the inspection plate and return to Step 1. If no damage is found, continue to Step 5.

### Step 5

– Release chain tension until impeller wheel and PTO turn freely (*See Idler Adjustment section below*).

## IDLER ADJUSTMENT

Remove the inspection plate on back of the gearbox. Visually inspect the UHMW plastic wear pad for wear or damage. Replace if needed. The idler adjustment yoke has two (2) nuts (*See illustration below*). Nut A holds the idler assembly against the chain and Nut B acts as a jam nut to lock the assembly in position. Reinstall inspection plate using quality grade silicone sealant under the inspection plate.

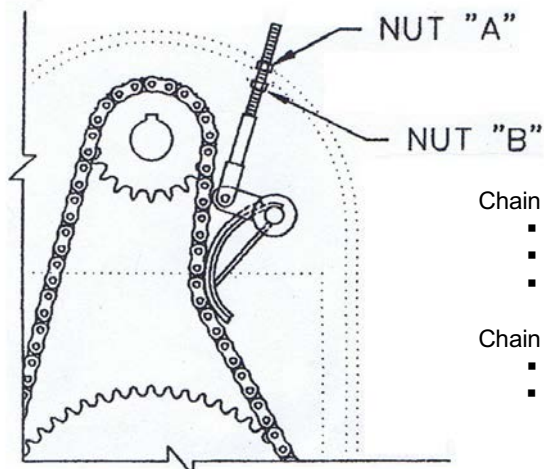

Chain needs **MORE** tension:

- Loosen Nut B
- Tighten Nut A to apply tension on chain
- Tighten Nut B to secure the assembly

Chain needs **LESS** tension:

- Loosen Nut A until desired tension is reached
- Tighten Nut B to secure the assembly



**PARTS LIST – STRUCTURAL COMOPONENTS**

ITEM	PART #	DESCRIPTION	QTY	ITEM	PART #	DESCRIPTION	QTY	
A	--	<b>HYD. HOSES &amp; SHAFT SHIELD ASSY</b>	--	F	--	DEPTH INDICATOR ASSY	--	
A1	001120	HEX NUT 3/8-16UNC	2	*F1	003860	*INDICATOR BRACKET	1	
A2	002238	HOSE RETAINER	2	*F2	001015	*HEX HEAD CAP SCREW 3/8-16UNC X 1-1/2 GRADE 5	2	
A3	000980	HEX HEAD CAP SCREW 1/2-20UNC X 1 GRADE 5	4	*F3	003975	*INDICATOR NEEDLE	1	
A4	003745	PTO SHIELD	1	*F4	001255	*HEX LOCK NUT 3/8-16UNC	4	
A5	002015	HYD. HOSE 3/8 X 14'-6" WIRE W/ 1/2 NPT MALE END	1	*F5	003865	*INDICATOR ADJUSTOR ROD	1	
A6	002020	HYD. HOSE 3/8 X 15'-6" WIRE W 1/2 NPT MALE END	1	*F6	001940	*INDICATOR ADJUSTOR EYE	1	
A7	001830	90° SWIVEL FITTING	2	*F7	000997	*HEX HEAD CAP SCREW 5/16-18UNC X 3/4 GRADE 5	1	
A8	001165	SPLIT LOCK WASHER 1/4	4	*F8	001185	*FLAT WAHER 3/8	3	
A9	001906	ISO TIP	2					
				*INDICATES TIEMS <b>NOT</b> SUPPLIED AS INDIVIDUAL COMPONENTS				
B	--	<b>MAIN FRMAE ASSEMBLY</b>		G1	002110	DOUBLE ACTION HYD. CYLNDER 3-1/2 X 16	1	
B1	000948	HEX HEAD CAP SCREW 1-14UNF X 6-1/2 GRADE 8	1	G2	002133	HAIR PIN 1/8 X 1-1/2 (INCLUDED W/ G1)	2	
B2	--	MAIN FRAME	1	G3	002132	CYLINDERMOUNTING PIN 1 X 3 (INCLUDED W/ G1)	3	
B3	003920	CLEVIS HITCH	1	G4	003890	CYLINDER TRANSPORT LOCK	1	
B4	001472	COTTER KEY 3/16 X 2	1	G5	001977	CYLINDER TRANSPORT LOCK RETAINING PIN	1	
B5	001461	SLOTTED HEX NUT 1-14UNF	1	G6	--	HIARPIN 1/8 X 1 (INC. W/ G5)	1	
B6	001909	JACK ASSEMBLY	1	G7	002102	CYLINDER KIT (NOT SHOWN)	1	
B7	003925	OPTIONAL CAT BLOCK HITCH	1					
C	--	<b>SIDE SHIELD ASSEMBLY</b>		H	--	<b>AXLE AND REAR FRAME ASSEMBLY</b>		
C1	001025	HEX HEAD CAP SCREW 1/2 -13UNC X 1/2 GRADE 5	2	H2	001285	HEX LOCK NUT 5/8-18UNF	6	
C2	003840	SIDE SHIELD BRACKET	1	H3	001405	HEX HEAD CAP SCREW 5/8-18UNF X 2 GRADE 8	2	
C3	00175	SPILT LOCK WASHER 1/2	3	H4	003995	AXLE ASSEMBLY PIN	2	
C4	001125	HEX NUT 1/2-13UNC	3	H5	002135	BOWTIE PIN	2	
C5	003837	SIDE SHIELD LOCK PLATE	1	H6	003869	TELESCOPING AXLE TUBE W/ SPINDLE	2	
C6	000949	REVERSING LOCK NUT 5/8-11UNC	1	H7	001415	HEX HEAD CAP SCREW 5/8-18UNF X 2-1/2 GRADE 8	4	
C7	001130	HEX NUT 5/8-11UNC	2	J	--	<b>SCOOP AND LOWER IMPELLER SHROUD ASSEMBLY</b>		
C8	00180	SPLIT LOCK WASHER 5/8	2	J1	001035	HEX HEAD CAP SCREW 1/2-13UNC X 2-1/2 GRADE 5	4	
C9	001155	PLAIN FLAT WASHER 5/8	4	J2	003790	LOWER IMPELLER SHROUD		
C10	003836	SIDE SHIELD HINGE PIN	1	J3	001125	HEX NUT 1/2-13UNC	4	
C11	001472	COTTER KEY 3/16 X 2	1	J4	001290	HEX LOCK NUT 3/4-16UNF	8	
C12	003835	UPPER SIDE SHIELD PLATE	1	J5	005004	SCOOP WELDMENT	1	
C13	003830	LOWER SIDE SHIELD PLATE	1	J6	001445	HEX HEAD CAP SCREW 3/4-16UNF X 2-1/2 GRADE 8	8	
C14	001490	HEX HEAD CAP SCREW 5/8-11UNC X 1-3/4 GRADE 5	2	J7	000846	FLAT HEAD SOCKET SCREW 5/8-11UNC X 2 GRADE 8	3	
C15	003836	SIDE SHIELD LOCK PIN	1	J8	003425	CUTTING EDGE	1	
C16	001034	HEX HEAD CAP SCREW 1/2-13UNC X 2-1/4 GRADE 5	1	J9	000949	REVERSING LOCK NUT 5/8-11UNC	3	
D	--	<b>UPPER IMPELLER SHROUD ASSEMBLY</b>		J10	001175	LOCK WSAHER 1/2	4	
D1	001360	HEX HEAD CAP SCREW 1/2-20UNF X 1-1/2 GRADEM8	5	K	--	<b>TIRE, WHEEL AND HUB ASSEMBLY</b>		
D2	003786	UPPER IMPELLER SHROUD	1	K1	001691	GREASE SEAL	2	
D3	001280	HEX LOCK NUT 1/2-20UNF	5	K2	001693/1694	INNER BEARING AND RACE	2	
E	--	<b>GEARBOX ASSEMBLY</b>		K3	001690	HUB ASSEMBLY (ITEMS K1, K2, K4, K8, K10)	2	
E1	000876	OIL FILL/BREATHER PLUG 1NPT	1	K4	001686/1696	OUTER BEARING AND RACE	2	
E2	--	GEARBOX WELDMENT	1	K5	001692	RETAINING WASHER	2	
E3	003750	INSPECTION COVER	1	K6	001689	SLOTTED HEX NUT 7/8-14UNF	2	
E4	001000	HEX HEAD CAP SCREW 3/8-16UNC X 3/4 GRADE 5	16	K7	001688	COTTER KEY 1/8 X 1-1/2	2	
E5	000870	OIL LEVEL CHECK PLUG 3/4NPT		K8	001687	DUST CAP	2	
E6	000885	OIL DRAIN PLUG 1/4NPT	1	K9	001685	WHEEL 8 X 15 – 6 HOLE	2	
E7	001405	HEX HEAD CAP SCREW 5/8-18UNF X 2 GRADE 8	6	K10	001697	WHEEL BOLT 7/16-14UNC	12	
E8	001285	HEX LOCK NUT 5/8-18UNF	6	K11	002260	TIRE 11L15	2	
E9	001170	LOCK WASHER 3/8	16			UPDATED NOVEMBER 2019		



PARTS ILLUSTRATION – STRUCTURAL COMPONENTS

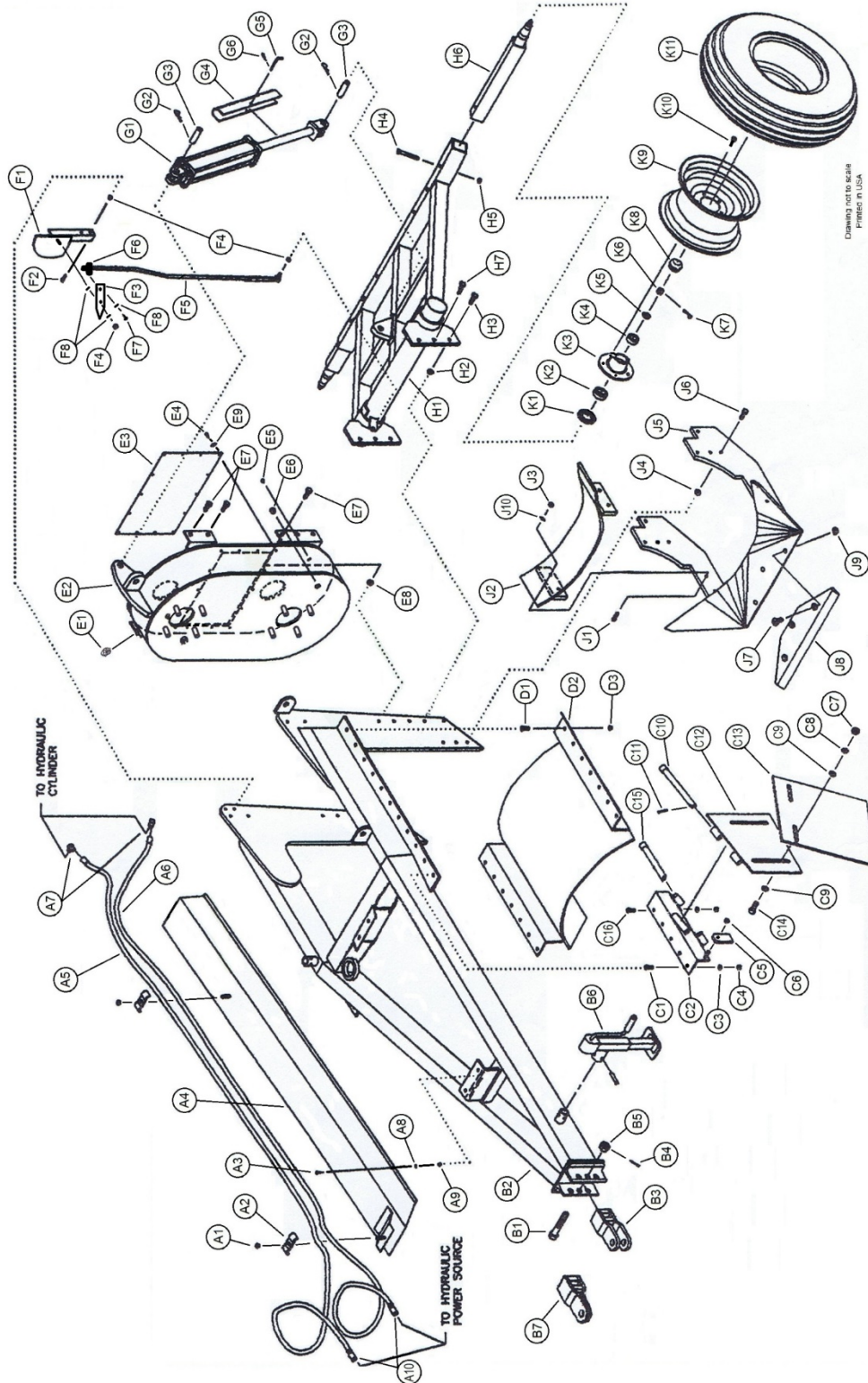

PARTS LIST – MECHANICAL LIST

ITEM	PART #	DESCRIPTION	QTY
L	--	<b>PTO/DRIVE SHAFT AND BEARING ASSEMBLY</b>	
L1	000680 / 000690	PTO SHAFT COMPLETE (INCLUDES ITEMS L4-L19) ****	1
L2	000685 / 000695	PTO SHAFT FRONT HALF (INCLUDES ITEMS L4-L11) ****	1
L3	000700	PTO SHAFT REAR HALF (INCLUDES ITEMS L8,L11-L19)	1
L4	001005	SHEAR BOLT - HHCS 3/8-16UNC X 1 GR. 5 OR GR. 8	2
L5	000725 / 000735	PTO SAFETY SLIDE LOCK ASSEMBLY ****	1
L6	000740 / 000750	SHEAR YOKE ASSEMBLY ****	1
L7	001255	HEX LOCK NUT 3/8-16UNC	2
L8	001890	UNIVERSAL JOINT 1-3/4 55 SERIES	2
L9	000820	YOKE AND SHAFT	1
L10	000770	PTO OUTER GUARD (FRONT HALF)	1
L11	000715	RETAINER & NYLON KIT (NOT SHOWN)	2
L12	003193	SQUARE KEY 5/8 X 2-7/8	1
L13	000775	PTO INNER GUARD (REAR HALF)	1
L14	000785	YOKE, TUBE AND SLIP SLEEVE	1
L15	000815	YOKE 1-3/4 KEYPED	1
L16	000209	PILLOW BLOCK BEARING 1-3/4	2
L17	001370	HEX HEAD CAP SCREW 1/2-20UNF X 2 GRADE 8	4
L18	003111	SQUARE KEY 3/8 X 1-7/8	3
L19	001280	HEX LOCK NUT 1/2-20UNF	4
L20	003159	DRIVE SHAFT 1-3/4 X 6'	1
L21	001470	FLAT WASHER 1/2	4
L22	000130	FLANGE BALL BEARING 2-7/16	2
L23	002781	SQUARE KEY 5/8 X 4-3/4	1
L24	003165	UPPER SHAFT 2-7/16 X 17-1/4	1
L25	000135	FLANGE BALL BEARING WITH CAP 2-7/16	2
L26	002782	SQUARE KEY 5/8 X 3	1
L27	003175	LOWER SHAFT 2-7/16 X 17-1/4	1
L28	001320	HEX HEAD CAP SCREW 3/8-16UNC X 3-1/2 GRADE 8	1
L29	002812	SET SCREW 3/8-16 X 1/4	7
L30	002811	SET SCREW 3/8-16 X 3/8	3
L31	001255	HEX LOCK NUT 3/8-16UNC	1
L32	000765	U-JOINT & YOKE ASSEMBLY	1
L33	000225	BEARING CAP 2-7/16 (INCLUDED WITH L25)	2
L34	001285	HEX LOCK NUT 5/8-18UNF	16
M	--	<b>IMPELLER ASSEMBLY</b>	
M1	000946	HEX HEAD CAP SCREW 1-14UNF X 4 GRADE 8	4
M2	001040	SHEAR BOLT (HEX HEAD CAP SCREW 1/2-13UNC X 3 GRADE 5)	4
M3	003330	PADDLE	4
M4	003760	IMPELLER WHEEL	1
M5	001265	HEX LOCK NUT 1/2-13UNC GRADE 5	4
M6	001461	SLOTTED HEX NUT 1-14UNF GRADE 8	4

ITEM	PART #	DESCRIPTION	QTY
M7	001472	COTTER PIN 3/16 X 2	4
M8	001405	HEX HEAD CAP SCREW 5/8-18UNF X 2 GRADE 8	1
M9	001180	SPLIT LOCK WASHER 5/8	1
M10	003970	RETAINING WASHER	1
M11	--	SOCKET CAP SCREW 1/2-13UNC X 1-1/2 (INCLUDED WITH M12)	3
M12	000440	TAPER BORE BUSHING 3535	1
N	--	<b>CHAIN TENSIONING ASSEMBLY</b>	
N1	004026	IDLER WELDMENT	1
N2	002813	WOODRUFF KEY 1/4 X 1 #15	1
N3	004027	SPACER 1 ID X 3/8 APPROXIMATELY	1
N4	000434	BUSHING 1"	1
N5	001090	HEX HEAD CAP SCREW 5/16-24UNF X 1-1/4 GRADE 5	4
N6	000525	OIL SEAL 1"	1
N7	--	SOCKET SET SCREW 3/18-16UNC X 1/2 (INCLUDED WITH N8)	1
N8	004028	IDLER ARM	1
N9	001130	HEX NUT 5/8-11UNC	2
N10	004029	IDLER ADJUSTING YOKE	1
N11	001110	HEX NUT 1/4-20UNC	4
N12	001165	SPLIT LOCK WASHER 1/4	4
N13	003659	UHMW PAD	1
N14	001220	ELEVATOR BUCKET BOLT 1/4-20UNC X 1	4
N15	--	CLEVIS PIN 1/2 X 1-1/2 (INCLUDED WITH N10)	1
N16	--	COTTER KEY 1/8 X 3/4 (INCLUDED WITH N10)	1
O1	002272	LUCAS ISO 680 INDUSTRIAL GEAR OIL (3-1/2 GALLONS)	1
P	--	<b>ROLLER CHAIN AND SPROCKETS ASSEMBLY</b>	
P1	000545	DOUBLE STRAND ROLLER CHAIN D80 X 91"	1
P2	000306	21 TOOTH D80 SPROCKET	1
P3	--	SQUARE KEY 5/8 (INCLUDED WITH P4)	1
P4	000400	SPLIT TAPER BUSHING 2-7/16	1
P5	003956	UPPER FRONT SPACER 2-7/16 ID	1
P6	--	HEX HEAD CAP SCREW 3/8-16UNC X 1-3/4 (INCLUDED WITH P4)	3
P7	000350	60 TOOTH D80 SPROCKET	1
P8	--	SQUARE KEY 5/8 (INCLUDED WITH P9)	1
P9	000405	SPLIT TAPER BUSHING 2-7/16	1
P10	003957	UPPER REAR SPACER 2-7/16 ID	1
P11	003959	LOWER FRONT SPACER 2-7/16 ID	1
P12	003958	LOWER REAR SPACER 2-7/16 ID	1
P13	--	HEX HEAD CAP SCREW 3/8-16UNC X 1-3/4 (INCLUDED WITH P9)	3
P14	000480	D80 OFFSET LINK	1
P15	000465	D80 CONNECTING LINK	1

PARTS ILLUSTRATION – MECAHNICAL COMPONENTS

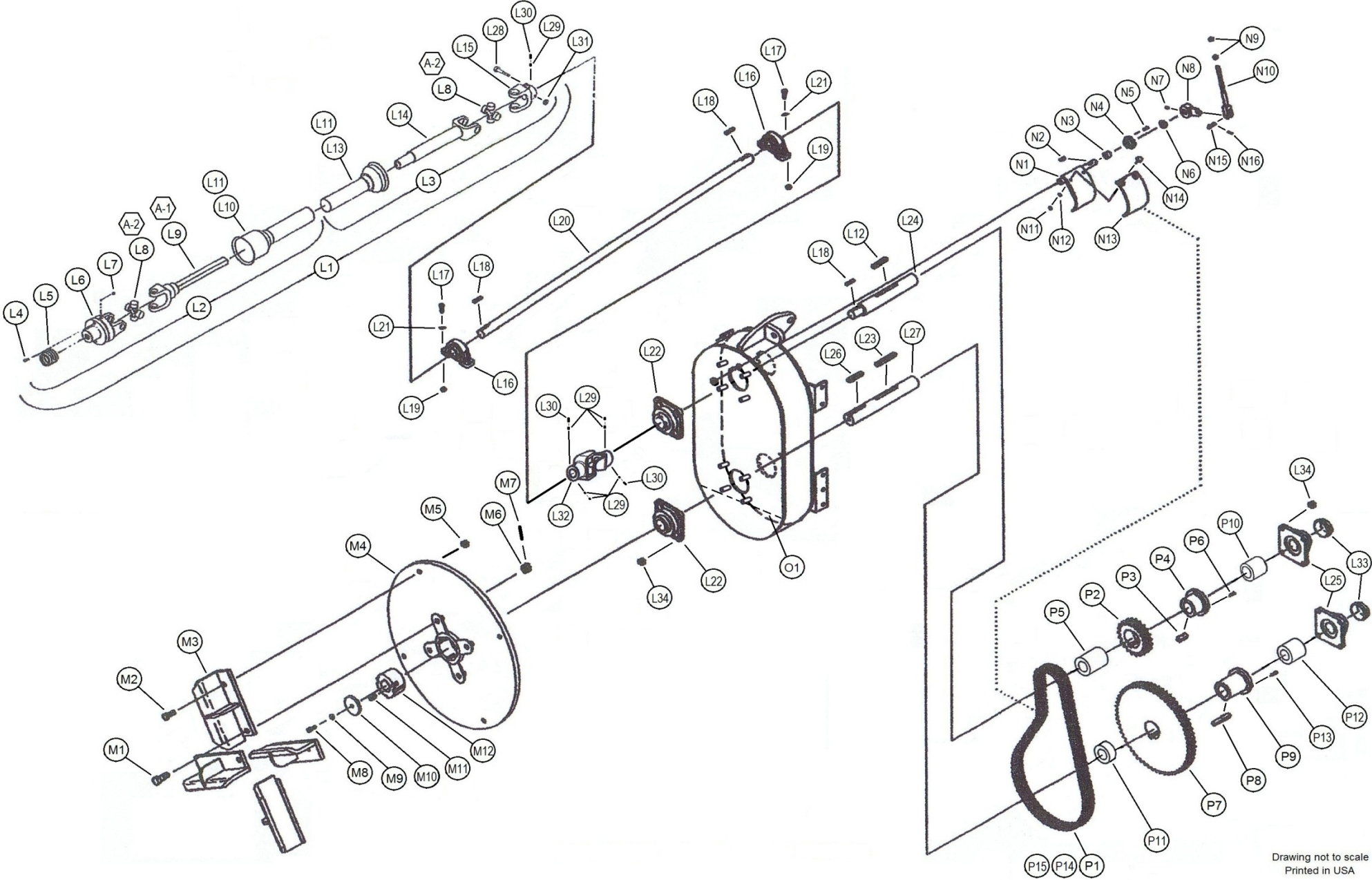

Drawing not to scale  
Printed in USA

## PARTS LIST – OPTIONAL COMPONENTS

ITEM	PART #	DESCRIPTION	QTY
Q	004010	<b>DEFLECTOR SHIELD ASSEMBLY (INCL. R1--R7, R24)</b>	
Q1	004012	DEFLECTOR SHIELD WELDMENT	1
R	004019	<b>TERRACING SHIELD ASSEMBLY (INCL. R1--R7, R13, R15--R17, R23--R24)</b>	
R1	002010	HYDRAULIC HOSE - 3/8 X 13'-6" 2 WIRE WITH 1/2NPT MALE END	1
R2	002015	HYDRAULIC HOSE - 3/8 X 14'-6" 2 WIRE WITH 1/2NPT MALE END	1
R3	002133	HAIR PIN 1/8 X 1-1/2 (INCLUDED WITH R6)	2
R4	002132	CYLINDER MOUNTING PIN 1 X 3 (INCLUDED WITH R6)	2
R5	001234	HEX NYLON INSERT LOCK NUT 3/4-10UNC	2
R6	002110	DOUBLE ACTING HYDRAULIC CYLINDER 3-1/2 X 16	1
R7	001080	HEX HEAD CAP SCREW 3/4-10UNC X 3-1/2 GRADE 5	2
	004020	<b>SHIELD EXTENSION ASSEMBLY (INCL. R8--R12, R14, R18--R22, R25--R27)</b>	
R8	001170	SPLIT LOCK WASHER 3/8	4
R9	001120	HEX NUT 3/8-16UNC GRADE 5	4
R10	004021	SHIELD EXTENSION BRACKET	2
R11	004024	CLEVIS PIN 1/2 X 1-3/4	2
R12	002135	BOWTIE PIN	2
R13	001220	ELEVATOR BUCKET BOLT 1/4-20UNC X 1	14
R14	001005	HEX HEAD CAP SCREW 3/8-16UNC X 1 GRADE 5	4
R15	001110	HEX NUT 1/4-20UNC	14
R16	001715	TERRACING SHIELD UHMW LINER	1
R17	004018	TERRACING SHIELD WELDMENT	1
R18	001025	HEX HEAD CAP SCREW 1/2-13UNC X 1-1/2 GRADE 5	2
R19	004022	SHIELD EXTENSION ADJUSTMENT BAR	2
R20	001716	SHIELD EXTENSION UHMW LINER	1
R21	004016	SHIELD EXTENSION	1
R22	001265	HEX LOCK NUT 1/2-13UNC	2
R23	001165	SPLIT LOCK WASHER 1/4	14
R24	001906	1/2" NPT ISO TIP	2
R25	001110	HEX NUT 1/4-20UNC	12
R26	001165	SPLIT LOCK WASHER 1/4	12
R27	001220	ELEVATOR BUCKET BOLT 1/4-20UNC X 1	12
S	003335	<b>HEAVY DEBRIS IMPELLER PADDLE (INCLUDES S1 THROUGH S5)</b>	1
S1	000840	FLAT HEAD SOCKET SCREW 1/2-13UNC X 2	4
S2	003360	BEVELED CUTTING EDGE	1
S3	003336	HEAVY DEBRIS IMPELLER PADDLE WELDMENT	1
S4	001265	HEX LOCK NUT 1/2-13UNC	4
S5	003365	PRIMARY CUTTING EDGE	1
s6	000930	1/2"-13 x 2" Plow bolt	2



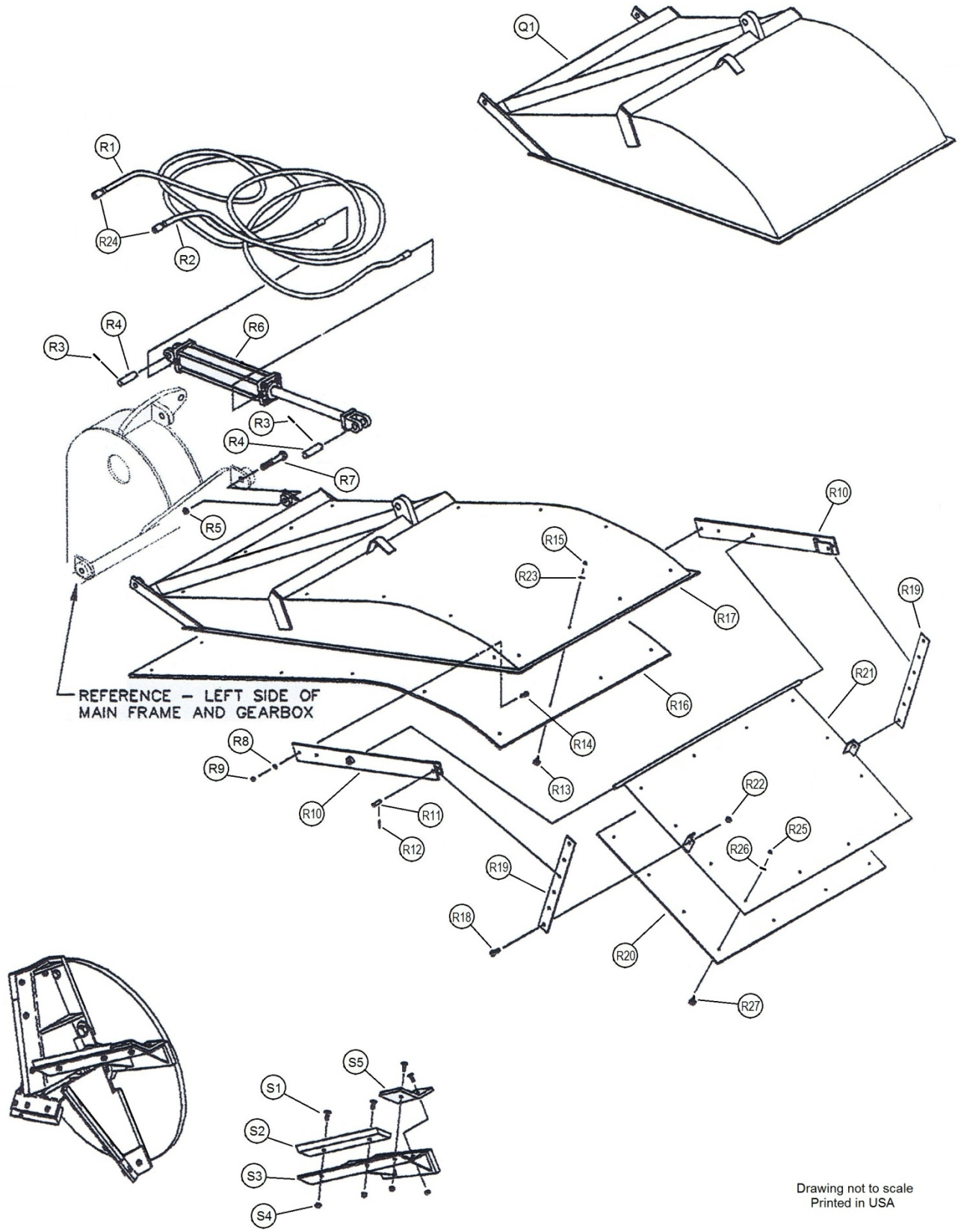

**LIMITED WARRANTY**

---

Hurricane Ditcher Company, Inc. shall be considered the "Company" throughout this warranty statement.

The Company warrants each new Company product to be free from defects in material and workmanship. This warranty is applicable only for the normal service life expectancy of the product or components, not to exceed twelve (12) consecutive months from the date of delivery of the new Company product to the end user for personal use. This warranty shall not exceed ninety (90) days from the date of delivery to the end user for commercial use.

Under no circumstances will it cover any merchandise or components thereof, which, in the opinion of the Company, has been subjected to misuse, unauthorized modifications, alterations, an accident, or if repairs have been made with parts other than those obtainable through the Company. The Company in no way warrants tires or other trade accessories since their respective manufacturers warrant these items separately. The Company's obligation under this warranty shall be limited to repairing or replacing free of charge to the original purchaser, any part that, in the Company's judgment, shall show evidence of such defect, provided further that such part shall be returned within thirty (30) days from the date of failure to the Company routed through the dealer and distributor from whom the purchase was made, transportation charges prepaid.

This warranty shall not be interpreted to render the Company liable for injury or damages of any kind or nature to person or property. This warranty does not extend to the loss of crops, loss because of delay in harvesting, or any expense or loss incurred for labor, substitute machinery, rental or for any other reason.

Except as set forth above, the Company shall have no obligation or liability of any kind on the account of any of its equipment and shall not be liable for special or consequential damages. The Company makes no other warranty, expressed or implied, and specifically, the Company disclaims any implied warranty or merchantability or fitness for a particular purpose. Some states or provinces do not permit limitations or exclusions of implied warranties or incidental or consequential damages, so the limitations or exclusions in this warranty may not apply in those areas.

This warranty is subject to any existing conditions of supply, which may directly affect our ability to obtain materials or manufacture replacement parts. The Company reserves the right to make improvements in design or changes in specifications at any time, without incurring any obligation to owners of units previously sold. No one is authorized to alter, modify, or enlarge this warranty. To enhance warranty, replace decals when worn, damaged or missing.

No warranty will be issued for bearing failure resulting from material wrapping around impeller shaft.

This warranty is not valid unless registered with Company within 30 days from the date of delivery to the end user.

HURRICANE DITCHER COMPANY, INC.  
2425 Cathlinette Road  
Vincennes, IN 47591  
812-886-9663  
[www.hurricane-ditcher.com](http://www.hurricane-ditcher.com)  
[info@hurricane-ditcher.com](mailto:info@hurricane-ditcher.com)





# THE HURRICANE

---

---

# MODEL 24

# DITCHER-TERRACER



**HURRICANE DITCHER CO., INC.**

2425 Cathlinette Rd.  
Vincennes, IN 47591

812-886-9663 Fax 812-886-0530

[www.hurricane-ditcher.com](http://www.hurricane-ditcher.com)

e-mail: [info@hurricane-ditcher.com](mailto:info@hurricane-ditcher.com)

